

*This document/data is the property of NITROX Solutions Inc. You may not possess, use, copy, or disclose this document/data or any information contained therein, for any purpose, including without limitation to design, manufacture, or repair parts without NITROX Solutions Inc express written permission. Neither receipt nor possession of this document alone, from any source, constitutes such permission. Possession, use, copying, or disclosing by anyone without NITROX Solutions Inc express written permission is not authorized and may result in criminal and/or civil liability. This document/data remains the property of NITROX Solutions Inc.

REVISIONS					
ZONE	REV.	DESCRIPTION	DATE	DRAWN	APPROVED
	A	RELEASE	4/25/2017	MJG	
A1, A3, B2, B3, C4	B	ORIENTED REAR FEET INTO CORRECT POSITION, UPDATED ALL VIEWS/DIMS TO MATCH, ADDED FILTER REMOVAL DIMENSIONS	8/16/2022	8/16/2022	

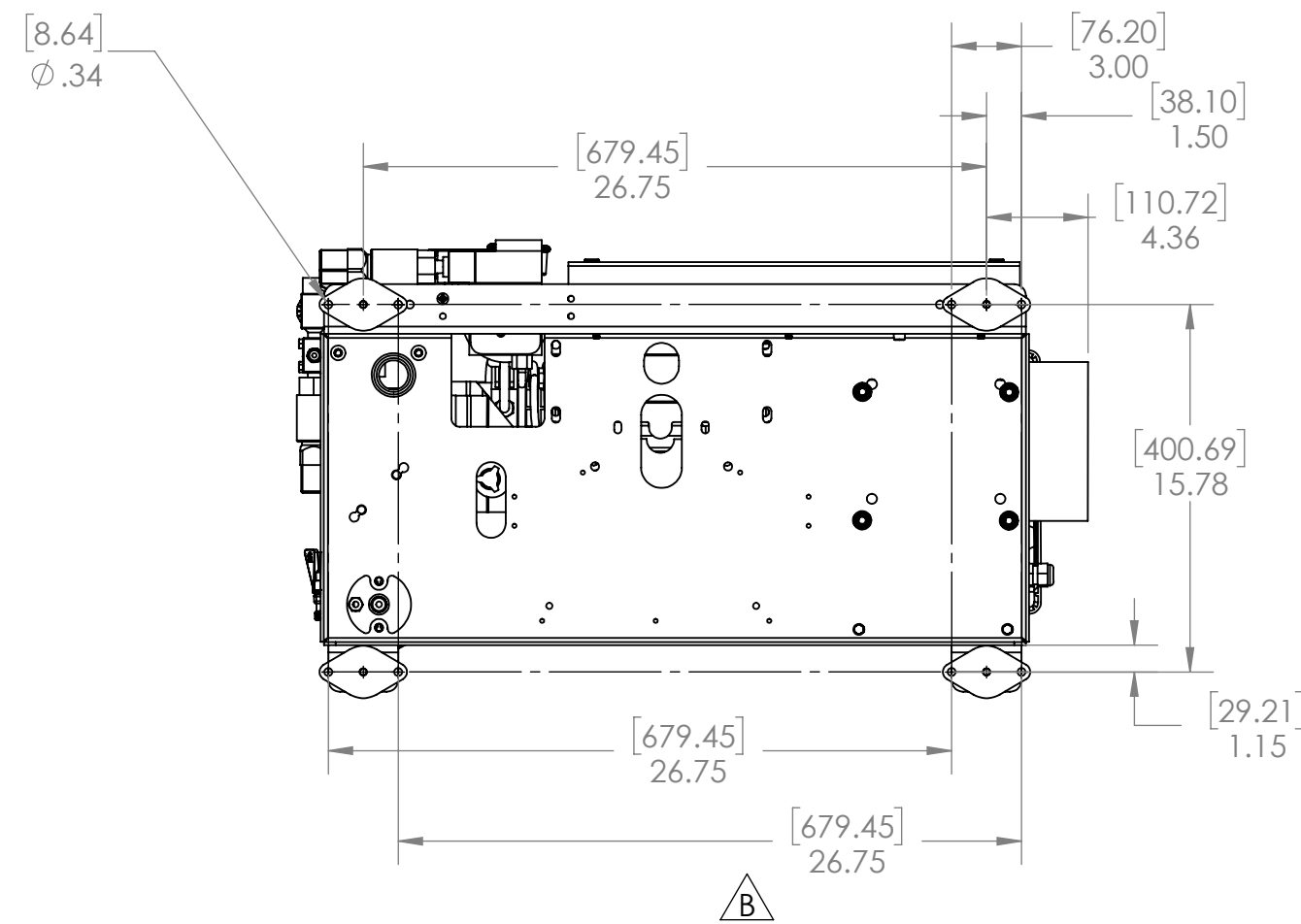
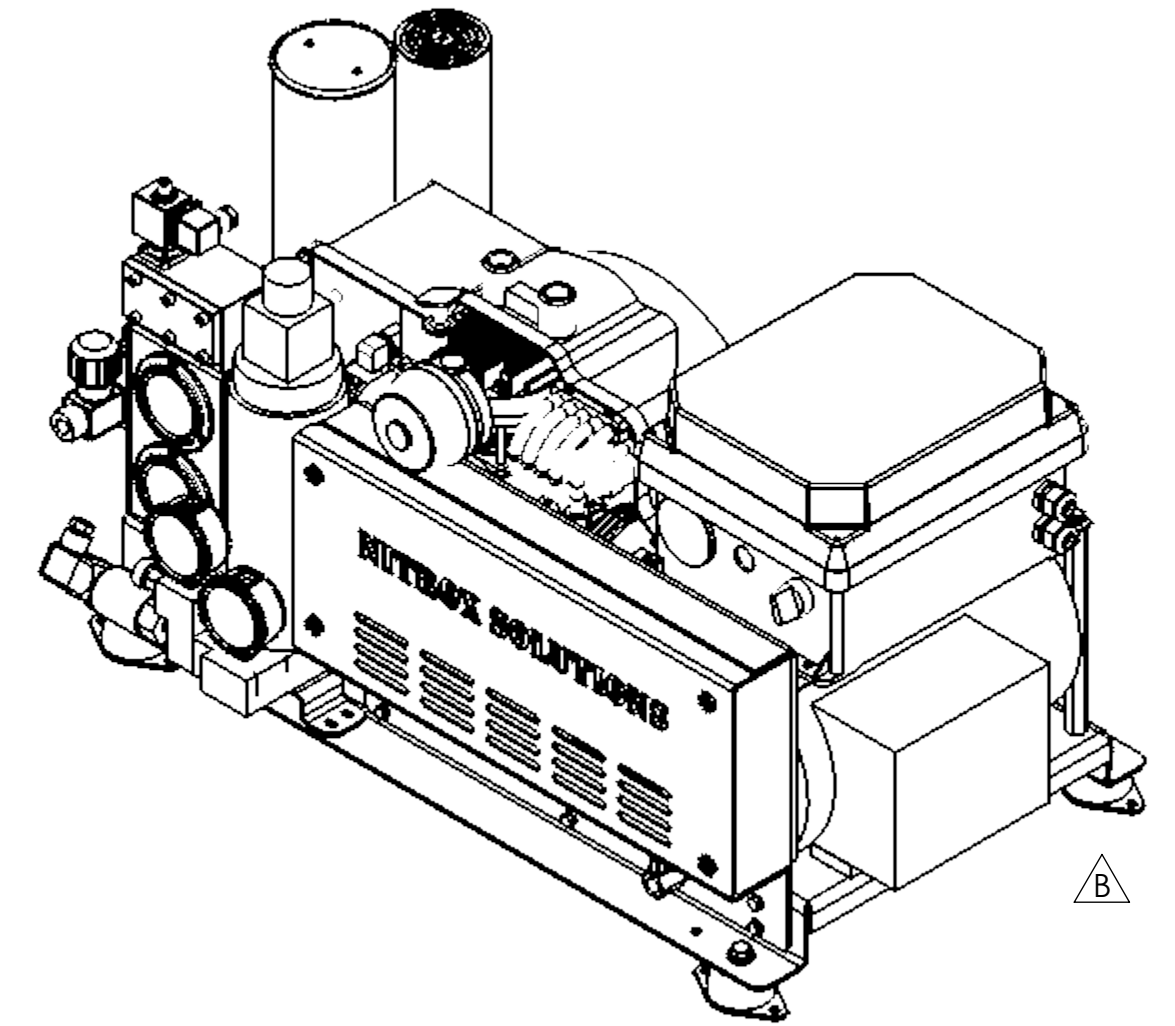
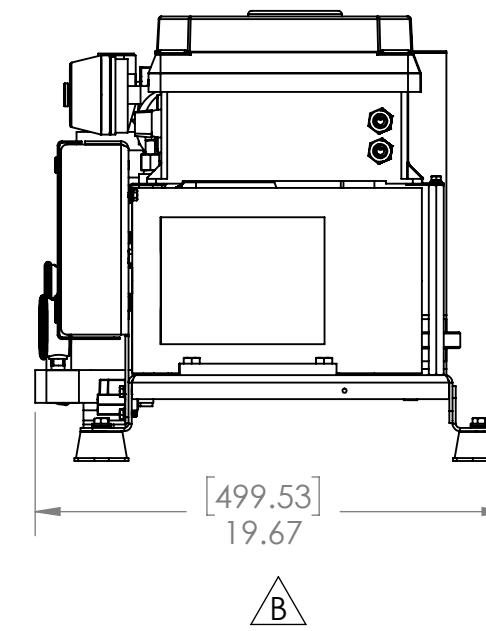
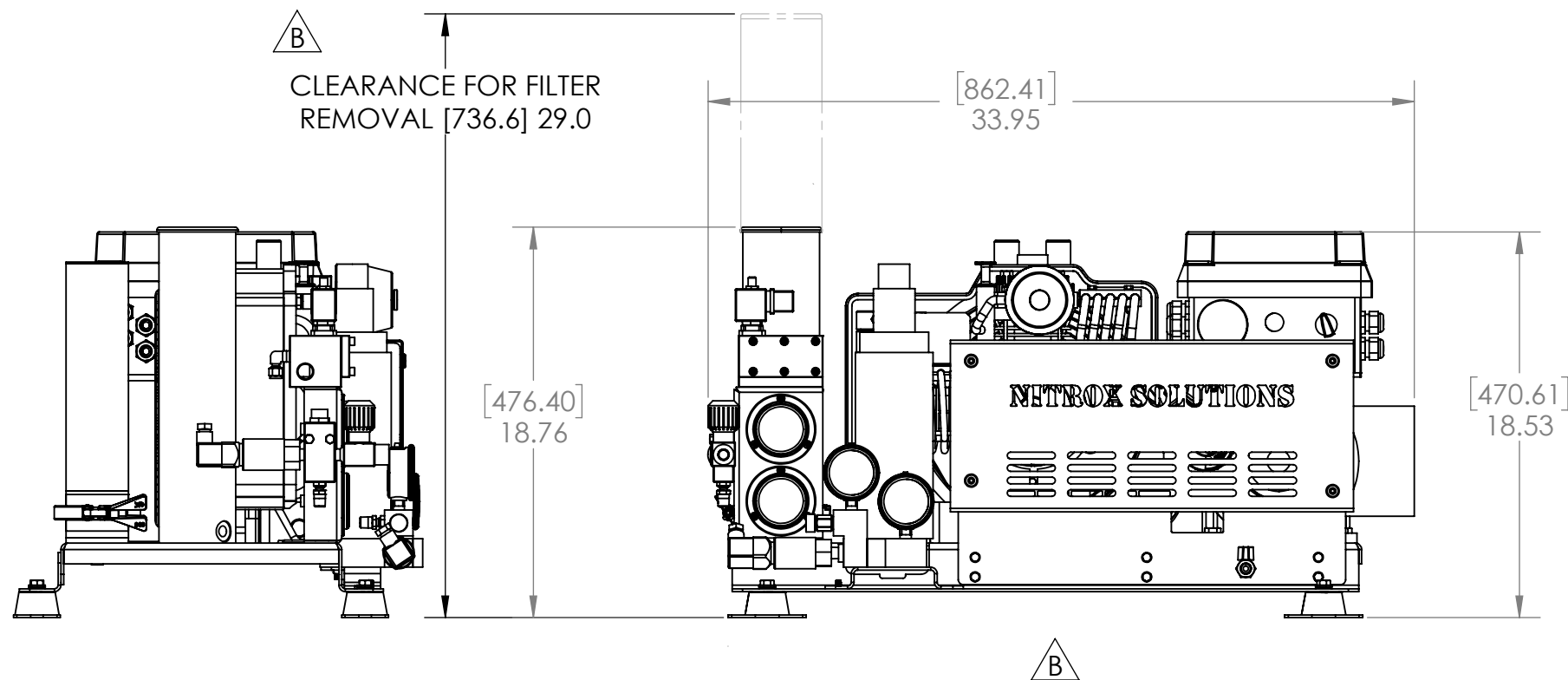
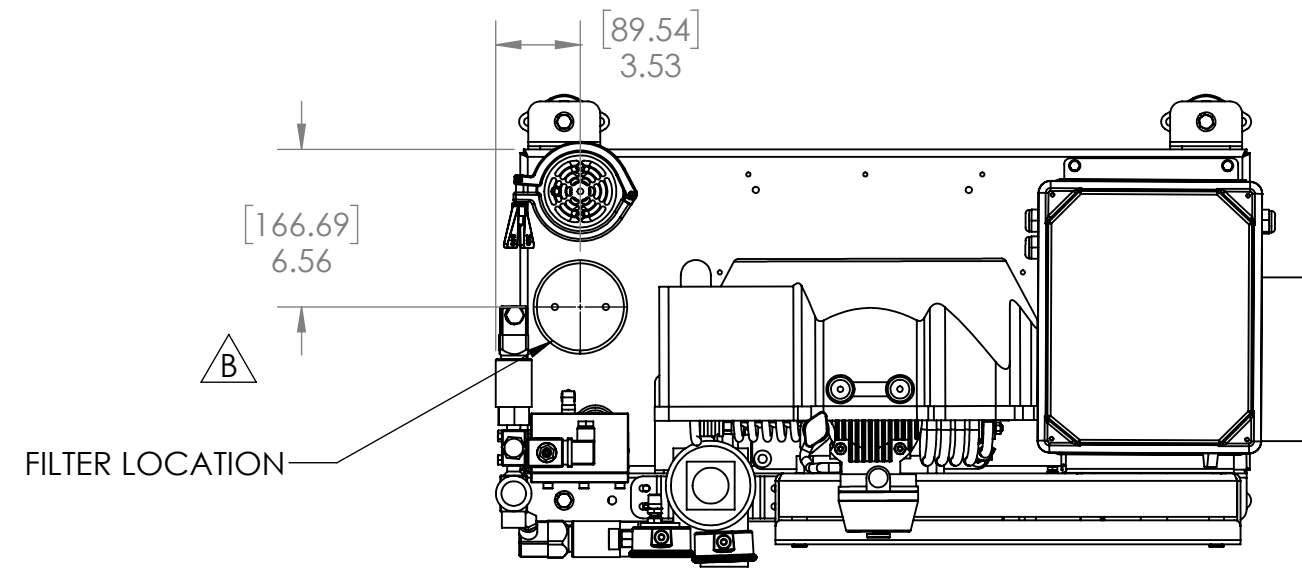

UNLESS OTHERWISE SPECIFIED DIMENSIONS ARE IN INCHES

- INTERPRET DRAWING PER ASME Y14.5M-1994
- DIMENSIONAL LIMITS APPLY AFTER PLATING/FINISH
- REMOVE BURRS AND BREAK CORNERS MAX = .010
- CHAMFER OR DEBURR HOLES MAX = .010
- MAX SURFACE ROUGHNESS 125 µm

TOLERANCES
 0.X = ±.1
 0.XX = ±.01
 0.XXX = ±.005

ANGULAR: X° = ±1°
 0.X° = ±.5°

WEIGHT (REF)
 lbs.

Third Angle Projection

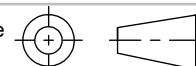

APPROVALS		DATE
DRAW	MJG	4/25/2017
CHECK		
ENGR		
CERT.		
APPROV.		

NITROX Solutions Inc
 2002 Davis Street - San Leandro, Ca 94577 USA

NOMENCLATURE
NS 350/450 AC ASSEMBLY

SCALE	SIZE	DRAWING NUMBER	REV	SHEET
1:6	C	100001	B	1 OF 1